

505

Digital Control for Steam Turbines with Redundancy



APPLICATIONS

The 505 controller is designed to operate industrial steam turbines of all sizes and applications. This steam turbine controller includes specifically designed algorithms and logic to start, stop, control, and protect industrial steam turbines or turbo-expanders, driving generators, compressors, pumps, or industrial fans. The 505 control's unique PID structure makes it ideal for applications where it is required to control steam plant parameters like turbine speed, turbine load, turbine inlet or exhaust header pressure, or tie-line power.

The control's special PID-to-PID logic allows stable control during normal turbine operation and bumpless control mode transfers during plant upsets, minimizing process over- or undershoot conditions. The 505 controller senses turbine speed via passive or active speed probes and controls the steam turbine through one or two (split-range) actuators connected to the turbine inlet steam valves.

For critical applications requiring increased reliability and redundancy, optionally two 505 controls can be connected in a redundant configuration to increase overall system availability. With this type of configuration, the two controls operate in a

master/slave manner, where the master unit controls all aspects of the turbine system, and the slave unit tracks the master unit's PIDs and control modes. This configuration allows for automatic and/or manual transfers between the two 505 controllers in cases of control, transducer, or actuator failure, or when on-line program changes are desired.

DESCRIPTION

The 505 control is packaged in an industrial hardened enclosure designed to be mounted within a system control panel located in a plant control room or next to the turbine. The control's front panel serves as both a programming station and operator control panel (OCP). This user-friendly front panel allows engineers to access and program the unit to the specific plant's requirements, and plant operators to easily start/stop the turbine and enable/disable any control mode. Password security is used to protect all unit program mode settings. The unit's two-line display allows operators to view actual and setpoint values from the same screen, simplifying turbine operation.

Turbine interface input and output wiring access is located on the controller's lower back panel. Unpluggable terminal blocks allow for easy system installation, troubleshooting, and replacement.

- Field-configurable steam turbine controller
- Integrated operator control panel
- Integrated first-out problem indicator logic
- User-friendly menu format
- Make minor program changes on-line (single unit)
- Make major program changes on-line (redundant units)
- Large LED display
- Modbus[®] communications
- Redundant (master/slave) operation for critical applications
- On-line repair and replacement (redundant units)
- Same form-fit-function as previous 505 versions

COST-EFFECTIVE DESIGN

The 505 control is designed to function as the turbine control, system sequencer, operator control panel, and first-out indicator. This encompassing design minimizes external system devices as well as system installation, wiring, and troubleshooting.

This field configurable controller allows major functional changes to be made at site, often by knowledgeable plant personnel, and minor functional changes to be on-line as process changes require. The 505 control's first-out-indicator logic indicates internal as well as external system related alarm and shutdown conditions, greatly simplifying and reducing system troubleshooting.

By simply applying two 505 controllers in a parallel and redundant configuration, users can cost effectively increase system reliability and availability.

COMMUNICATIONS

The 505 controls can communicate directly with plant Distributed Control Systems and/or CRT-based operator control panels, through two Modbus[®] * communication ports. These ports support RS-232, RS-422, and RS-485 communications using ASCII or RTU Modbus protocols.

Communications between the 505 and a plant DCS can also be performed through hardwired connections. Since all 505 PID setpoints can be controlled through analog input signals, interface resolution and control is not sacrificed.

*—Modbus is a trademark of Modicon, Inc.

REDUNDANCY

Optionally, two 505s can be applied in a parallel configuration to operate in a redundant master/slave manner. With this configuration, the master 505 controls all aspects of the turbine, and the slave 505 tracks the master unit's PID and control modes, allowing it to bumplessly take control of the turbine in cases of control, transducer, actuator, or other system failures. Optionally, users can force manual transfers between units to verify operation, make on-line changes, or replace system devices. The 505 is designed to interface with Woodward's redundant CPC offerings.

SYSTEM PROTECTION

- Integral Overspeed Protection Logic
- First-out Indication (10 individual shutdown inputs)
- Bumpless transfer between control modes if a transducer failure is detected
- Local/Remote Control priority and selection
- Fail-safe Shutdown Logic

CONTROL

The following PIDs are available to perform as process controllers or limiters:

- Speed/Load PID (with Dual Dynamics)
- Auxiliary PID (limiter or control)
- Cascade PID (Header Pressure or Tie-Line Control)

CONTROL SPECIFICATIONS

INPUTS

- Power: 18–32 Vdc, 90–150 Vdc, 88–132 Vac (47–63 Hz), 180–264 Vac (47–63 Hz)

- Speed: 2 MPUs (1–30 Vrms) or proximity probes (24 Vdc provided), 0.5 to 15 kHz
- Discrete Inputs: 16 Contact Inputs (4 dedicated, 12 programmable)
- Analog Inputs: 6 Programmable Current Inputs (4–20 mA)

OUTPUTS

- Valve/Actuator Drivers: 2 Actuator Outputs (4–20 mA or 20–160 mA)
- Discrete Outputs: 8 Relay Outputs (2 dedicated, 6 programmable)
- Analog Outputs: 6 Programmable Current Outputs (4–20 mA)

COMMUNICATION

- Serial: 2 Modbus (ASCII or RTU) Comm Ports (RS-232, RS-422, or RS-485 compatible)

CONTROL ACCESSORIES

505View HMI (Human Machine Interface)

The 505View is an optional software program that provides a powerful computer-based OCP (operator control panel). This OCP uses graphical and intuitive computer screens to allow operators to easily interface to and control all aspects of the 505 controller. Once connected to a 505 controller, the 505View self-configures itself to display the correct application and control modes used by the 505 controller. See Woodward Product Specification 03207 for additional information.

Control Assistant (Configuration Management Tool)

The Woodward Control Assistant software program is a computer-based service tool that can be used with the 505 control to upload, save, and download controller configurations. Optionally, this service tool can also be used to trend unit parameters, to compare differences in configuration files, and to verify if control settings have been changed.

FUNCTIONALITY

The 505's control capabilities are:

- Speed/Frequency Control
- Turbine or Generator Load Control or Limiting
- Turbine Inlet Header Pressure Control or Limiting
- Turbine Exhaust Header Pressure Control or Limiting
- Plant Import/Export Power Control or Limiting
- Isochronous Load Sharing between units (with DSLC™ control)
- Control of any process directly related to unit load

FEATURES

- Critical Speed Avoidance (3 speed bands)
- Auto Start Sequence (hot & cold starts)
- Valve Limiter(s)
- Security (Program is Password Protected)
- Dual Speed/Load Dynamics
- First-Out Indication (Shutdowns)
- Zero Speed Detection with proximity probe (< 0.5 Hz)
- Peak Speed Indication for overspeed trip
- Two Programmable Functions Keys on the 505's front panel
- Hand Valve operation (using First Stage Pressure)
- Two independent Modbus comm links
- Remote analog setpoints for Speed/Load, Aux, and Cascade
- Program upload/download capability
- Feed-forward decoupling algorithm for compressors

OPERATING CONDITIONS

- 25 to +65 °C ambient air temperature range
- Optional NEMA type 4 (watertight and dust-tight, indoor/outdoor) enclosure for bulkhead mounting with a temperature range from -25 to +55 °C
- Approximate dimensions 14L x 11H x 4D inches (356 x 279 x 102 mm)

- Approximate bulkhead enclosure dimensions 20L x 20H x 7.6D inches (508 x 508 x 193 mm)
- Humidity: Lloyd's ENV2 test #1
- Dry heat: Lloyd's ENV3
- Salt fog: US MIL-STD-810 method 509.2 procedure 1
- Shock: meets US MIL-STD-810C, method 516.2-1, procedure 1B
- Vibration: Lloyd's ENV2 test #1
- Certifications: CE (18-32 Vdc version only), UL, and cUL

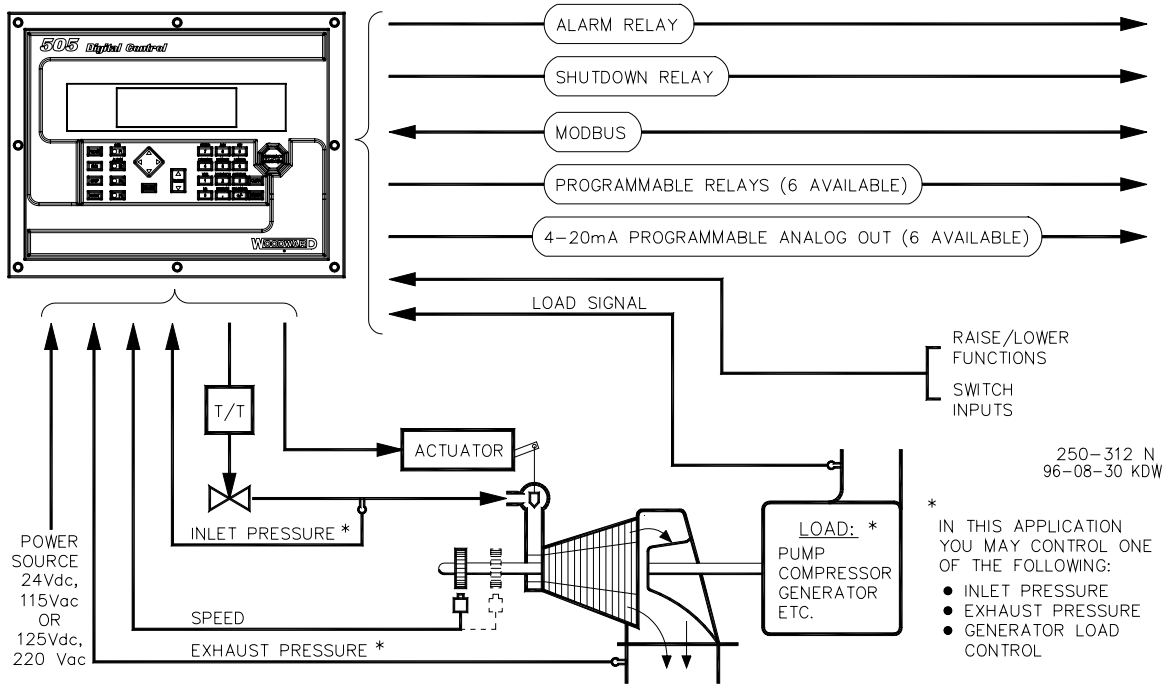

Controlled Single Valve Steam Turbine

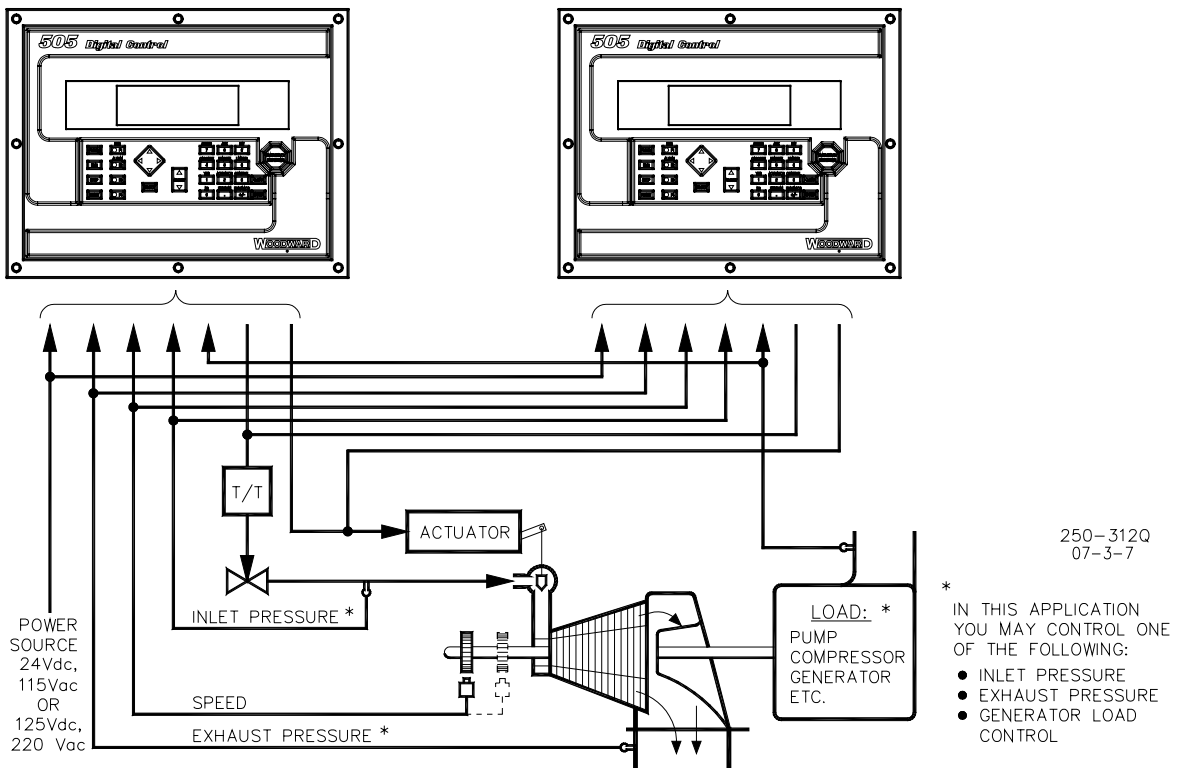

Redundant Controlled Single Valve Steam Turbine

PO Box 1519
 Fort Collins CO, USA
 80522-1519
 1000 East Drake Road
 Fort Collins CO 80525
 Tel.: +1 (970) 482-5811
 Fax: +1 (970) 498-3058

Distributors & Service
 Woodward has an international network of distributors and service facilities. For your nearest representative, call the Fort Collins plant or see the Worldwide Directory on our website.

www.woodward.com

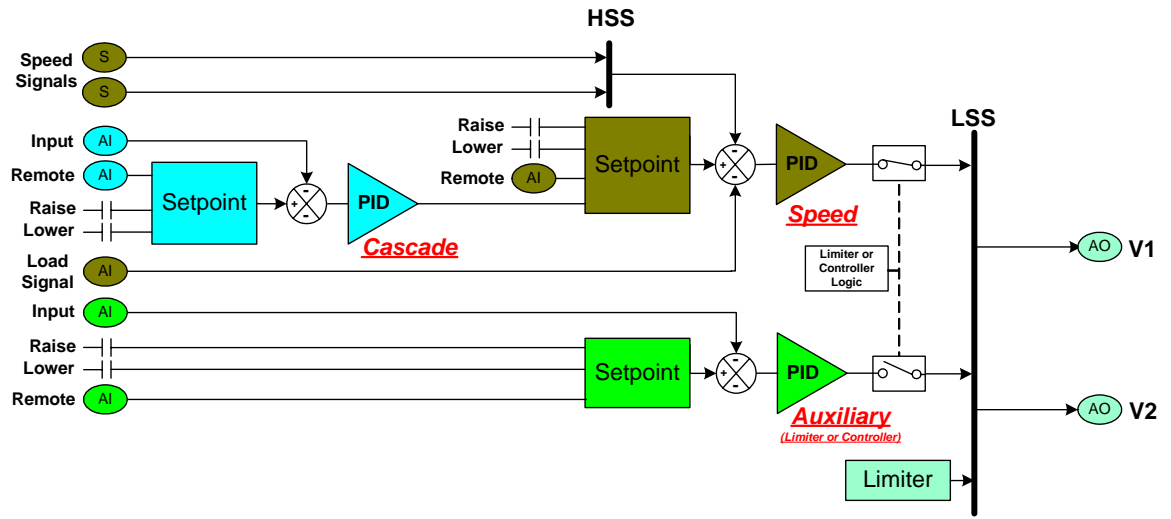

Basic Functional Control Diagram

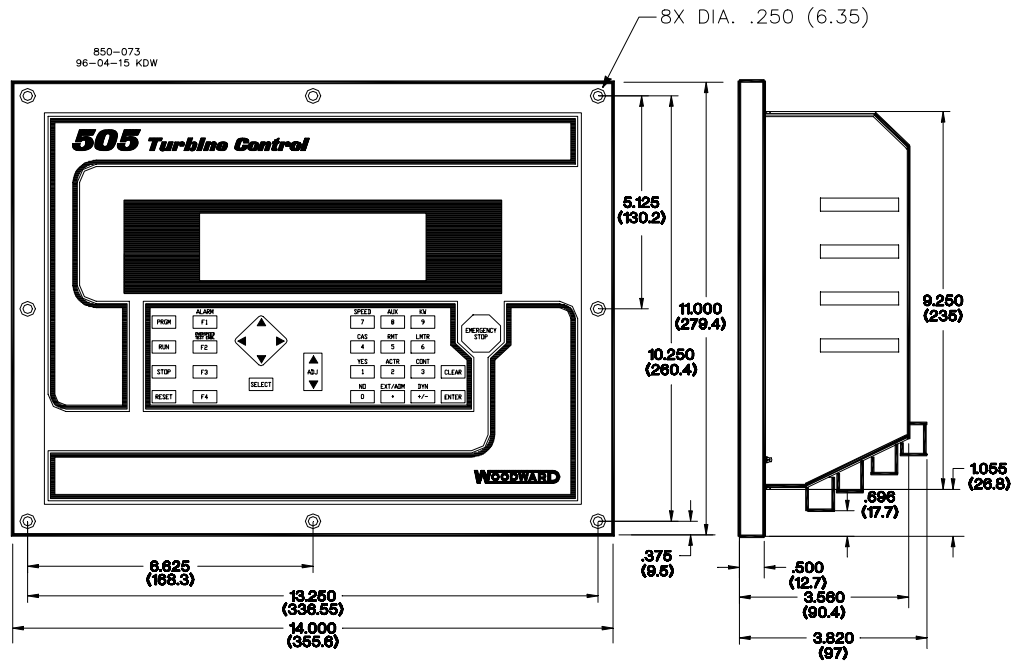

505 Dimensions
 (Do not use for construction)

This document is distributed for informational purposes only. It is not to be construed as creating or becoming part of any Woodward Governor Company contractual or warranty obligation unless expressly stated in a written sales contract.

© Woodward 2007
 All Rights Reserved

2007/3/Fort Collins

For more information contact:

